

**SERIES
4843**

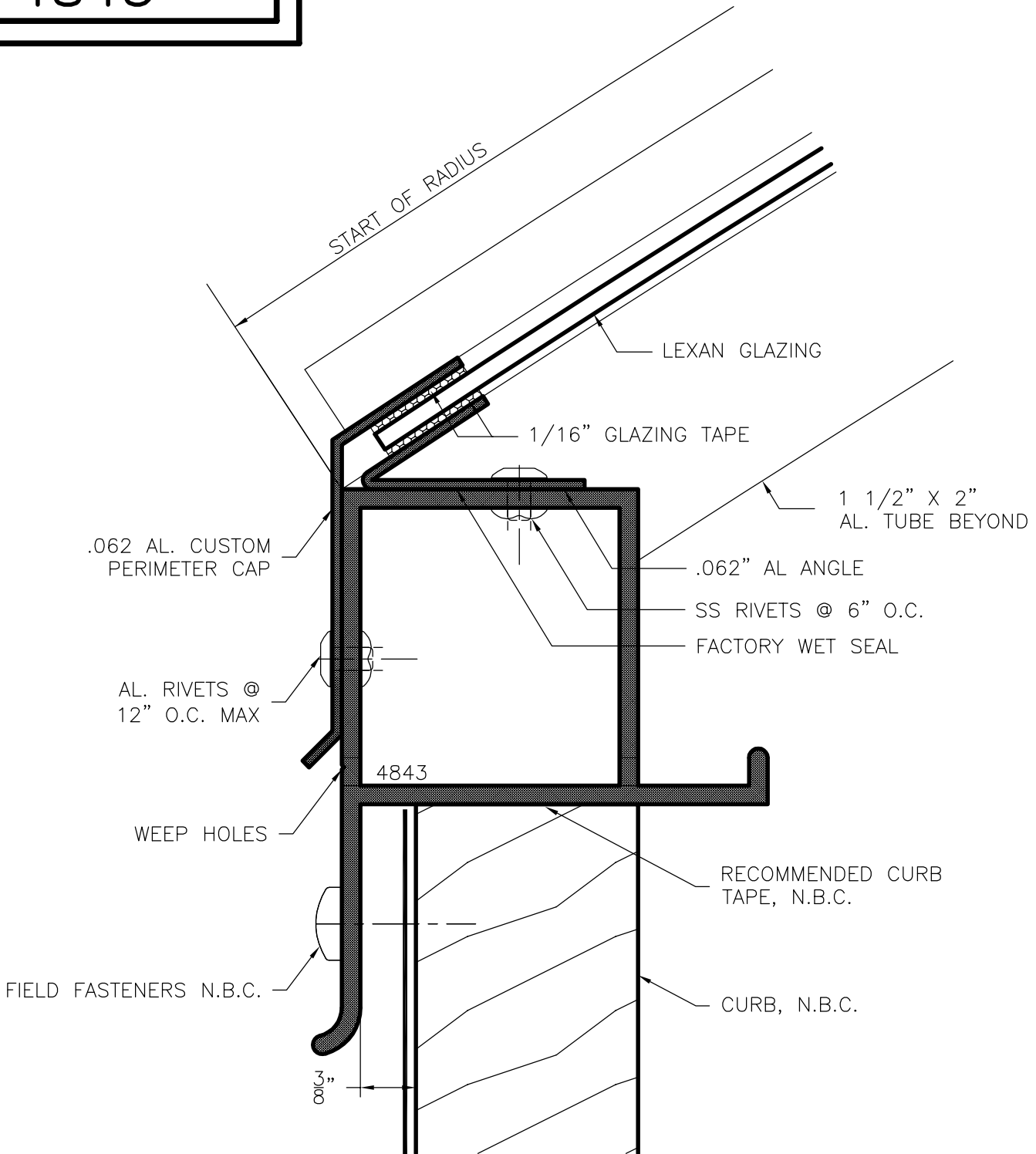

GENERIC GLAZING DETAILS.
ACTUAL DESIGN AND MAKE-UP VARY AS REQUIRED.

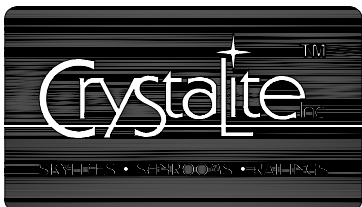

Barrel Vault Sill

NAMI certified and rated by NFRC for thermal performance; and certified in accordance to the NAFS Standard [AAMA/WDMA/CSA 101/1.S.2/A440] for air infiltration, water penetration and structural loading -as required by the IBC; commonly referred to as 'AAMA Testing.'